

HSF

NOTES:

- Rated Current:1.5AMP
- Contact Resistance:30mΩ max
- Withstand Voltage:500V AC/DC
- Insulation Resistance:1000MΩ min
- Operation Temperature:-20℃ to +80℃
- Contact Material:Brass
- Contact Plating:Au or Sn Over Ni
- Shell :SPCC Ni-Plating
- Insulator Material:High Temperature Plastic(UL94V-0)

Ordering Information

6231 - 25 F XX X 0 1

- No.of Pins 25: 24+1
- Contact Plating G0=Gold Flash G1=3u"Gold G2=5u"Gold G3=10u"Gold G4=15u"Gold G5=30u"Gold S0=Gold Flash/Tin S1=3u"Gold/Tin S2=5u"Gold/Tin S3=10u"Gold/Tin S4=15u"Gold/Tin S5=30u"Gold/Tin SN=Tin
- Color B=Black W=White G=Grey

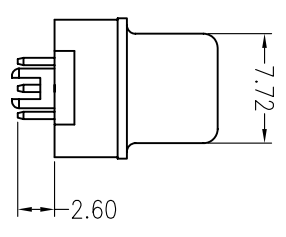
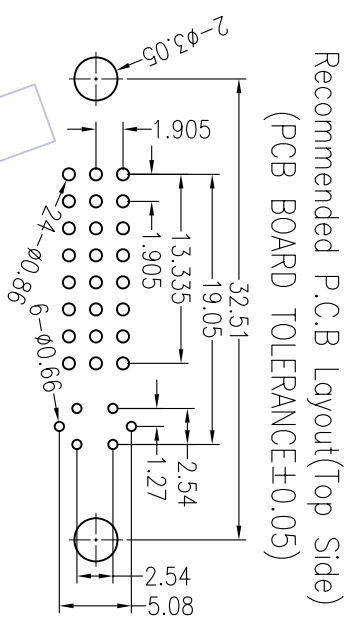
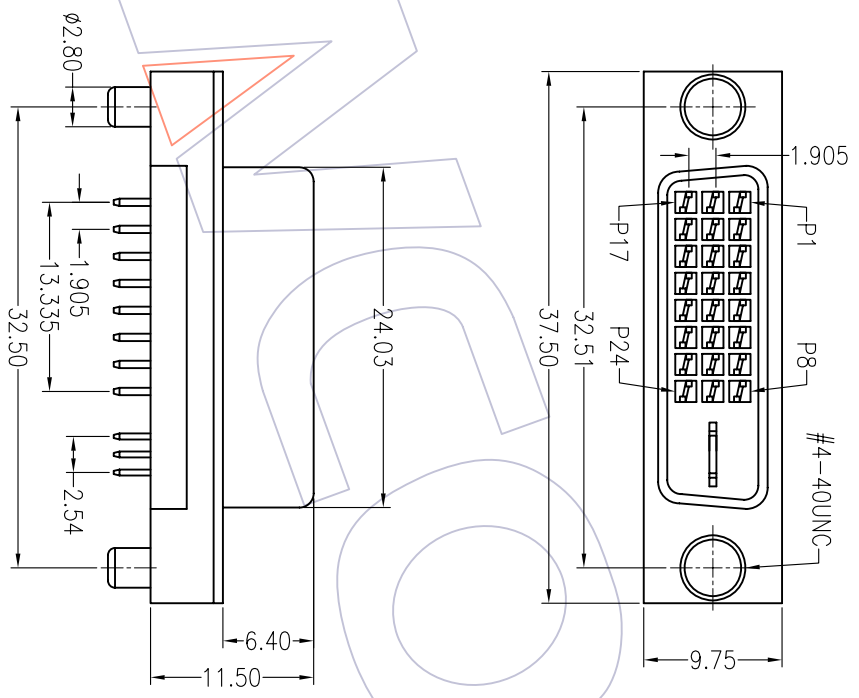

REV	DATE	MODIFICATION DESCRIPTION	CHANGE	APPROVE	OPERATION		DRAW		SCALE		PART NO.	TITLE:
					XXX	±0.40	Millium Clear	09/03/02	UNIT	1:1		
A0	09/03/02	NEW			XXX	±0.25	DESIGN		A4		6231-25FXXX01	DVI FEMALE 24+1 180° DIP
					XXX	±0.15	CHECK		1/1			
					Angle	± 3'	APPROVE					

WCON 维峰五金电子有限公司
WAVE HARDWARE ELECTRONICS CO.,LTD