

# HSF

**NOTES:**

- Rated Current:3.0AMP
- Contact Resistance:30mΩ max
- Withstand Voltage:500V AC/DC
- Insulation Resistance:1000MΩ min
- Operation Temperature:-40℃ to +85℃
- Contact Material:Brass
- Contact Plating:Au or Sn Over Ni
- Shell Material: Zinc Alloy&Steel
- Shell plating: Ni or Sn over Fe
- Insulator Material:Polyester(UL94V-0)

## Ordering Information

6230 - 29 M XX X 0 1

- No. of Pins 29: 24+5
- Contact Plating G0=Gold Flash G1=3u"Gold G2=5u"Gold G3=10u"Gold G4=15u"Gold G5=30u"Gold S0=Gold Flash/Tin S1=3u"Gold/Tin S2=5u"Gold/Tin S3=10u"Gold/Tin S4=15u"Gold/Tin S5=30u"Gold/Tin SN=Tin
- Color B=Black W=White G=Grey

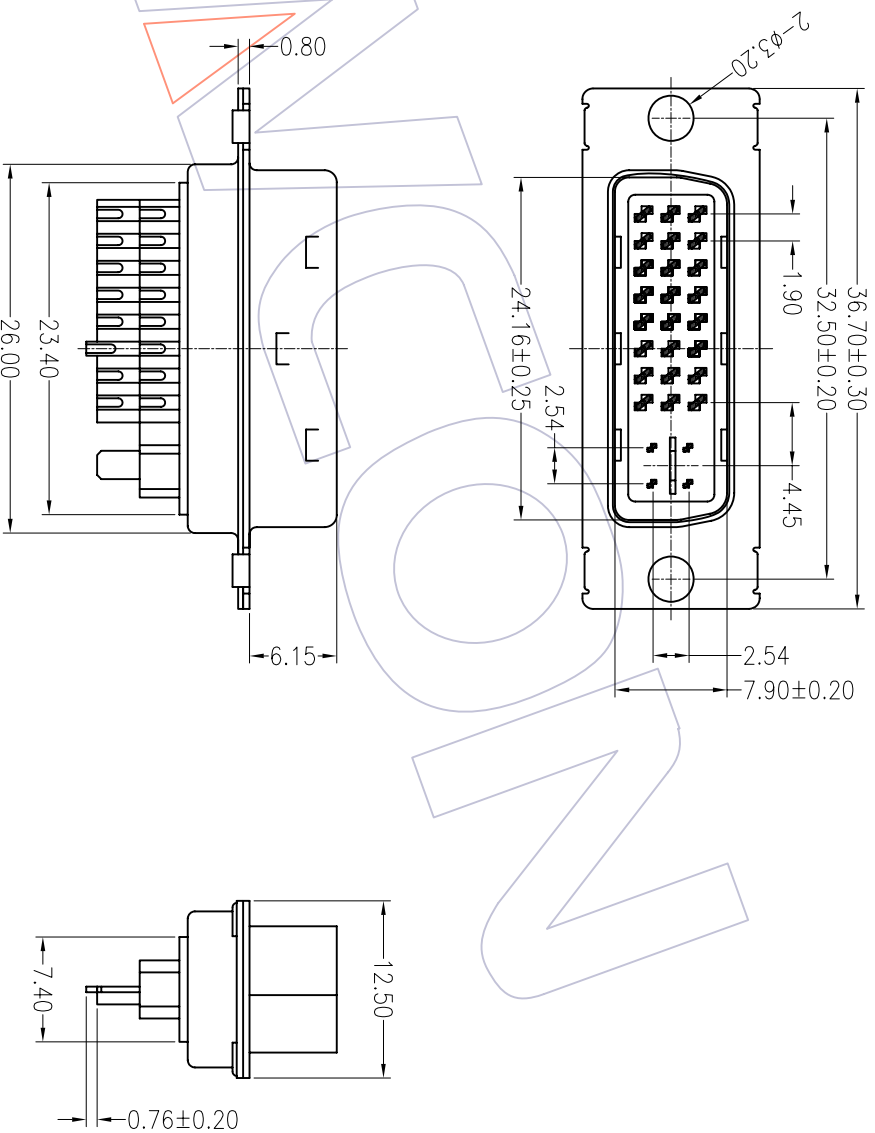

OPERATION	X.X	±0.40	DRAW	Millennium Class		SCALE	1:1
	X.XX	±0.25		DESIGN	UNIT		mm
X.XXX	±0.15	CHECK	SHEET	1/1	PART NO.	TITLE:	DVI MALE 24+5 SOLDER TYPE
	Angle						
REV	DATE	MODIFICATION DESCRIPTION	CHANGE	APPROVE			
A0	09/03/23	NEW					

**WCON** 维峰五金电子有限公司  
 WAFER HARDWARE ELECTRONICS CO., LTD

6230-29MXXX01