

HSF

NOTES:

- Rated Current:3.0AMP
- Contact Resistance:30mΩ max
- Withstand Voltage:500V AC/DC
- Insulation Resistance:1000MΩ min
- Operation Temperature:-40℃ to +85℃
- Contact Material:Brass
- Contact Plating:Au or Sn Over Ni
- Shell Material: Zinc Alloy&Steel
- Shell plating: Ni or Sn over Fe
- Insulator Material:Polyester(UL94V-0)

Ordering Information

6230 - 17 M XX X 0 1

- No.of Pins 17: 12+5
- Contact Plating G0=Gold Flash G1=3u"Gold G2=5u"Gold G3=10u"Gold G4=15u"Gold G5=30u"Gold S0=Gold Flash/Tin S1=3u"Gold/Tin S2=5u"Gold/Tin S3=10u"Gold/Tin S4=15u"Gold/Tin S5=30u"Gold/Tin SN=Tin
- Color B=Black W=White G=Grey

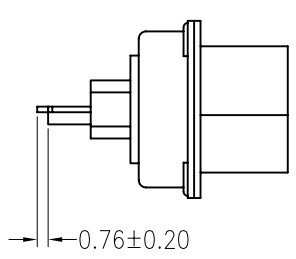
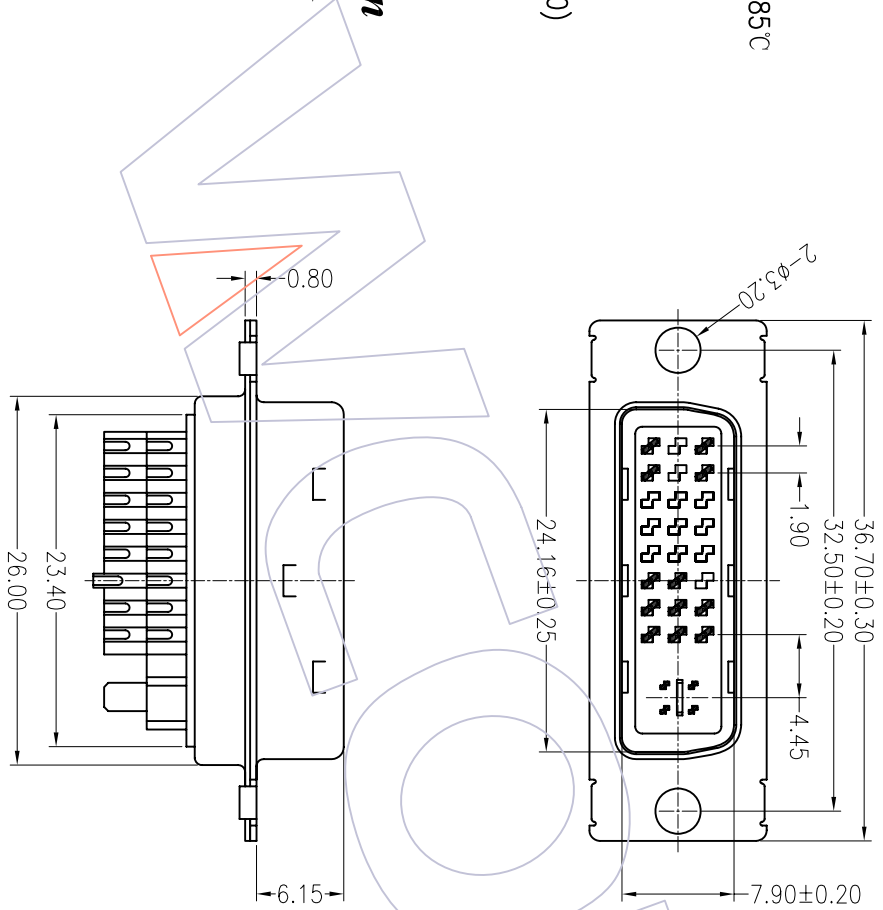

OPERATION	DRAW	Millennium Class	09/03/23	SCALE	1:1	<p>WCON 维峰五金电子有限公司 WAFER HARDWARE ELECTRONICS CO.,LTD</p>	PART NO.	6230-17MXXX01
X.X	DESIGN			UNIT	mm		TITLE:	DVI MALE 12+5 SOLDER TYPE
X.XX	CHECK			SIZE	A4			
X.XXX	APPROVE			SHEET	1/1			
Angle				PROJ.				
± 3'								
± 0.15								
± 0.25								
± 0.40								
CHANGE	APPROVE							
MODIFICATION DESCRIPTION								
NEW								
DATE								
09/03/23								
REV								
A0								