

HSF

NOTES:

Rated Voltage:100V AC/DC
 Rated Current:1.0AMP
 Contact Resistance:20mΩ max
 Withstand Voltage:250V AC/DC
 Insulation Resistance:100MΩ min
 Operation Temperature: -25°C to +85°C
 Contact Material:Brass
 Contact plating:Sn Over Ni
 Insulator Material:PA6T+30%G.F UL94V-0

Ordering Information

WF1251-W Z XX X X 1

No. of Pins
 02-15P
 Color
 B=Beige A=Tray
 W=White T=Tube
 R=Tray&Reel
 Packing
 A=Tray
 T=Tube
 R=Tray&Reel

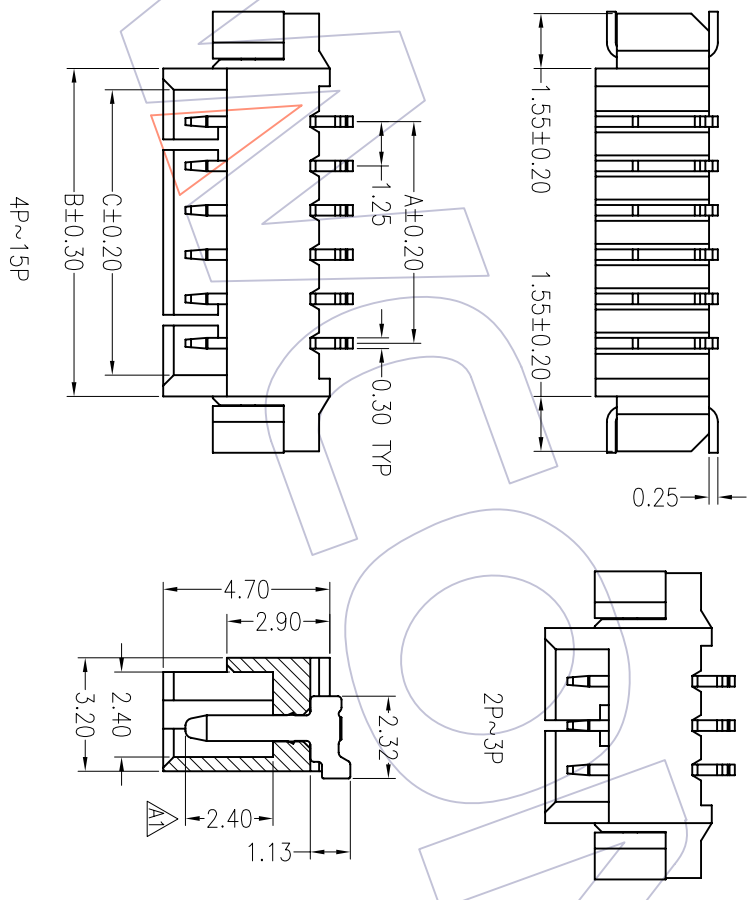

Recommended P.C.B Layout(Top Side)
 (PCB BOARD TOLERANCE±0.05)

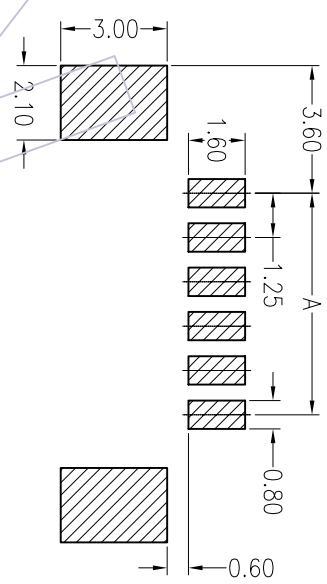

Specification & Ordering Information:

Circuit	Part No.	Dimension			Q'ty /Tube
		A	B	C	
02	WF1251-WZ02XX1	1.25	4.25	3.05	75
03	WF1251-WZ03XX1	2.50	5.50	4.30	64
04	WF1251-WZ04XX1	3.75	6.75	5.55	56
05	WF1251-WZ05XX1	5.00	8.00	6.80	50
06	WF1251-WZ06XX1	6.25	9.25	8.05	45
07	WF1251-WZ07XX1	7.50	10.50	9.30	41
08	WF1251-WZ08XX1	8.75	11.75	10.55	37
09	WF1251-WZ09XX1	10.00	13.00	11.80	34
10	WF1251-WZ10XX1	11.25	14.25	13.05	31
11	WF1251-WZ11XX1	12.50	15.50	14.30	30
12	WF1251-WZ12XX1	13.75	16.75	15.55	28
13	WF1251-WZ13XX1	15.00	18.00	16.80	26
14	WF1251-WZ14XX1	16.25	19.25	18.05	25
15	WF1251-WZ15XX1	17.50	20.50	19.30	24

WCON 维峰五金电子有限公司
 WAVE HARDWARE ELECTRONICS CO. LTD

REV	DATE	MODIFICATION DESCRIPTION	CHANGE	APPROVE	OPERATION		DRAW	2012.04.04	08.09.04	SCALE	
					XXX	±0.40				UNIT	1:1
A1	08/09/04	Change the Dimension			XXX	±0.25	DESIGN			mm	
A0	08/07/19	NEW			XXX	±0.15	CHECK			A4	
					Angle	± 3'	APPROVE			1/1	
					DIM	TOL				PROJ.	
										Customer NO.	

SBB TAB
 MX1.25 Wafer 90° SMT