

HSF

NOTES:

Current Rating: 1.5AMP
 Contact Resistance: 20mΩ max
 Withstand Voltage: 500V AC/DC
 Insulation Resistance: 1000MΩ min
 Operation Temperature: -40°C to +105°C

Contact Material: Brass
 Contact plating: Au or Sn Over Ni
 Insulator Material: PA6T+30%GF (UL94V-0)

Ordering Information

3121A-XX R XX BK00 X 1

- | | | | |
|-------------|-------------------|-----------------|-----------|
| No. of Pins | Contact Plating | Color Insulator | Packaging |
| 10 30 | G0=Gold Flash | B=Black | A=Tray |
| 14 34 | G1=3u"Gold | U=Blue | T=Tube |
| 16 40 | G2=5u"Gold | W=White | |
| 20 44 | G3=10u"Gold | | |
| 24 50 | G4=15u"Gold | | |
| 26 60 | G5=30u"Gold | | |
| | S0=Gold Flash/Tin | | |
| | S1=3u"Gold/Tin | | |
| | S2=5u"Gold/Tin | | |
| | S3=10u"Gold/Tin | | |
| | S4=15u"Gold/Tin | | |
| | S5=30u"Gold/Tin | | |
| | SN=Tin | | |

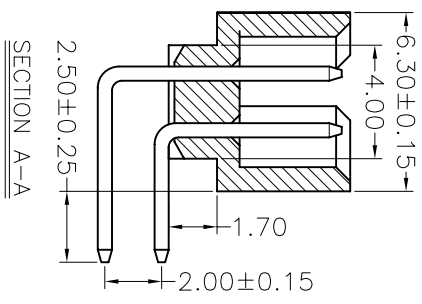
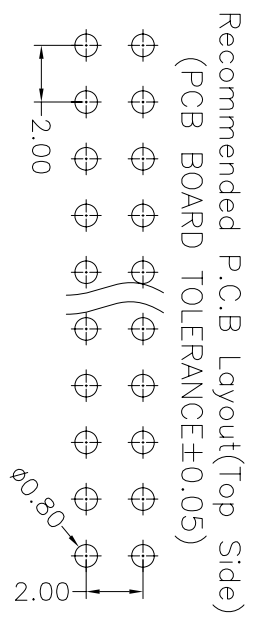
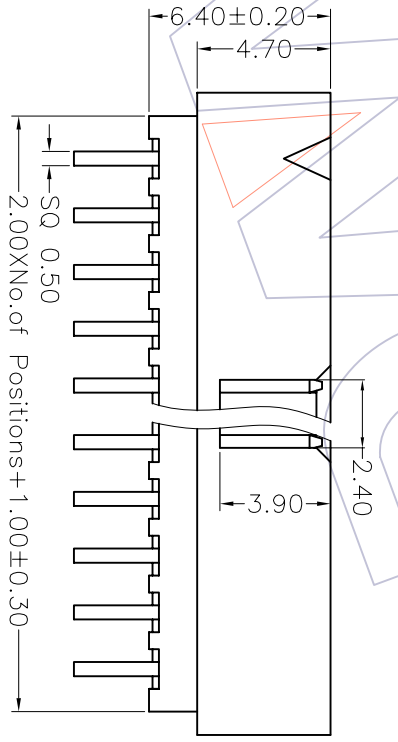
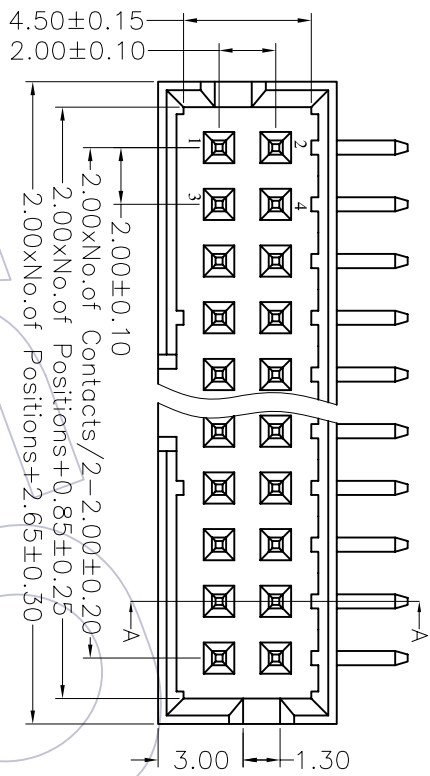

REV	DATE	MODIFICATION DESCRIPTION	CHANGE	APPROVE	OPERATION	DRAW	WEIXD	08/05/06	SCALE	4:1	 WCON 维峰五金电子有限公司 WAFE HARDWARE ELECTRONICS CO. LTD	PART NO.	3121A-XXRXXBK00X1
A0	08/05/06	NEW			XXX	DESIGN		UNIT	mm	SIZE		A4	TITLE:
					XXX	CHECK		SHEET	1/1	PROJ.		Customer NO.	
					Angle	APPROVE							
					± 3'								