

HSF

NOTES:

- Current Rating: 3AMP
- Contact Resistance: 20mΩ max
- Withstand Voltage: 500V AC/DC
- Insulation Resistance: 1000MΩ min
- Operation Temperature: -40°C to +105°C
- Contact Material: Brass
- Contact plating: Au or Sn Over Ni
- Insulator Material: PBT / PA6T + 30%G.F.(UL94V-0)

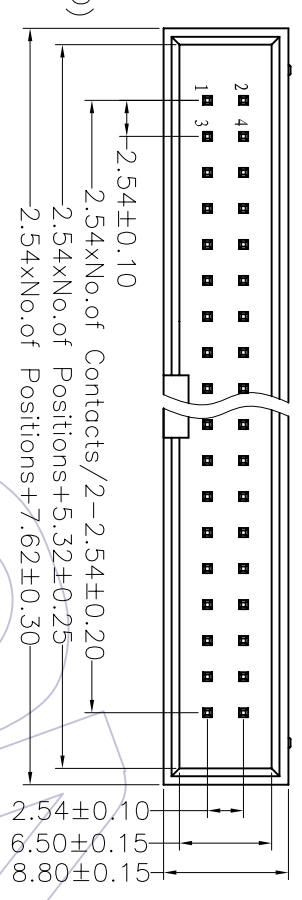
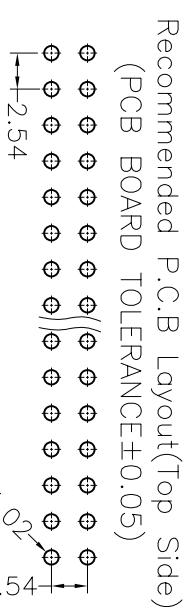

Ordering Information

3112-XX S XX B K00 X 1

- No.of Pins
10P 30P
14P 34P
16P 40P
20P 50P
24P 60P
26P 64P
- Contact Plating
G0=Gold Flash
G1=3u"Gold
G2=5u"Gold
G3=10u"Gold
G4=15u"Gold
G5=30u"Gold
- Color Insulator
B=Black
U=Blue
G=Gray(427C)
E=Gray(413C)
- Packing:
A=Tray
T=Tube
- S0=Gold Flash/Tin
S1=3u"Gold/Tin
S2=5u"Gold/Tin
S3=10u"Gold/Tin
S4=15u"Gold/Tin
S5=30u"Gold/Tin
SN=Tin

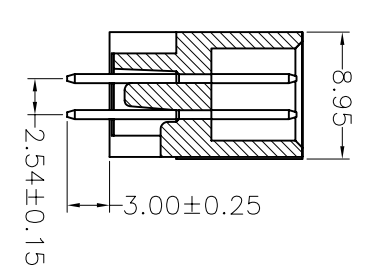
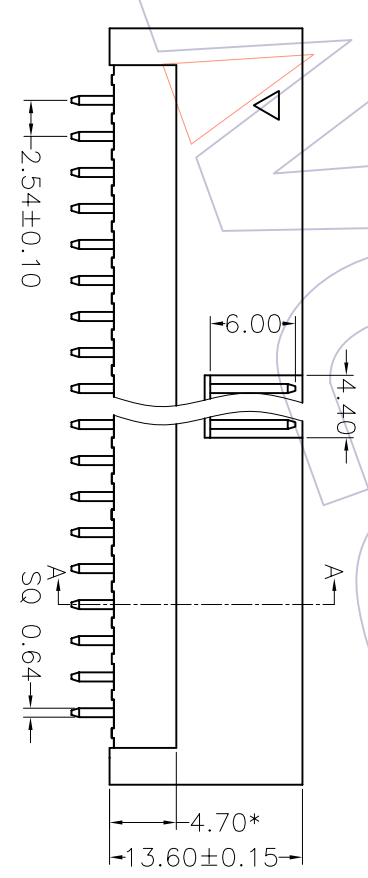

SECTION A-A

| REV | DATE | MODIFICATION DESCRIPTION | CHANGE | APPROVE | OPERATION | DRAW | WEIXD | SCALE | PART NO. | TITLE: |
|-----|----------|--------------------------|--------|---------|--|-----------------|----------|-----------|------------------|-----------------------------|
| A0 | 08/05/08 | NEW | | | XXX ±0.40 XXX ±0.25 XXX ±0.15 Angle ± .3' | DESIGN CHECK | 08/05/08 | A4 1/1 | 3112-XXSXXBK00X1 | 2.54 BOX HEADER 180° H=13.6 |
| | | | | | | | | | | |

WCON 维峰五金电子有限公司
WAVE HARDWARE ELECTRONICS CO.,LTD