

HSF

NOTES:

Current Rating: 3AMP
 Contact Resistance: 20mΩ max
 Withstand Voltage: 500V AC/DC
 Insulation Resistance: 1000MΩ min
 Operation Temperature: -40°C to +105°C

Contact Material: Brass
 Contact plating: Au or Sn Over Ni
 Insulator Material: PBT/PA6T+30%G.F.(UL94V-0)

Ordering Information

3110-XX S XX B D00 X1

No. of Pins: 6P, 24P, 8P, 26P, 10P, 30P, 12P, 34P, 14P, 40P, 16P, 50P, 18P, 60P, 20P, 64P
 Contact Plating: G0=Gold Flash, G1=3u"Gold, G2=5u"Gold, G3=10u"Gold, G4=15u"Gold, G5=30u"Gold, S0=Gold Flash/Tin, S1=3u"Gold/Tin, S2=5u"Gold/Tin, S3=10u"Gold/Tin, S4=15u"Gold/Tin, S5=30u"Gold/Tin, SN=Tin
 Color Insulator: B=Black, U=Blue, G=Gray(427C), E=Gray(413C)
 Packing: A=Tray, T=Tube

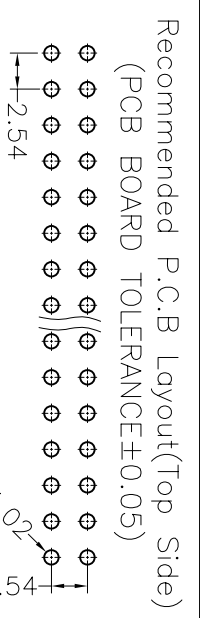
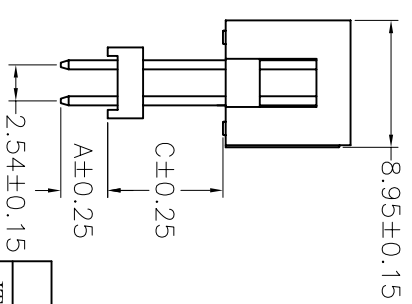
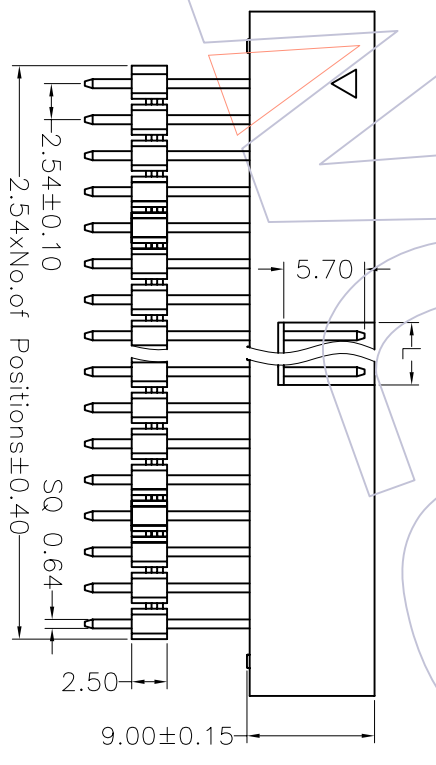
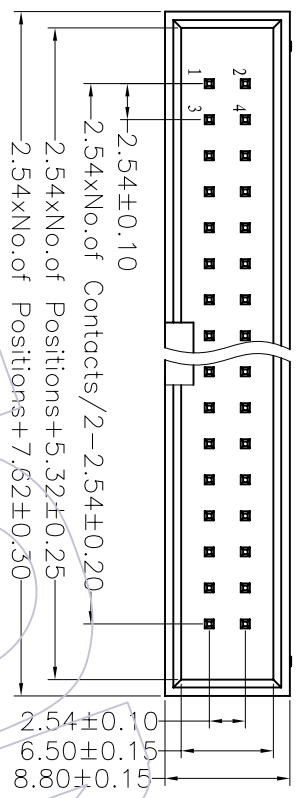

Dimension parentheses list			
ITEM	A	C	L
Standard	3.30		6-8P=4.0
Alternate			10-64P=4.4

REV	DATE	MODIFICATION DESCRIPTION	CHANGE APPROVE	OPERATION	DRAW	WEIXD	SCALE	UNIT	PART NO.	TITLE:
A0	08/05/08	NEW		X.X ±0.40	DESIGN	08/05/08	2:1	mm	3110-XXSXXBD00X1	2.54 BOX HEADER 180° H=9.0 ADD HOUSING
				X.XX ±0.25	CHECK			A4		
				X.XXX ±0.15	APPROVE			1/1		
				Angle ± 3'						Customer NO.

WCON 维峰五金电子有限公司
 WAFER HARDWARE ELECTRONICS CO., LTD