

HSF

NOTES:

Current Rating: 3AMP
 Contact Resistance: 20mΩ max
 Withstand Voltage: 500V AC/DC
 Insulation Resistance: 1000MΩ min
 Operation Temperature: -40°C to +105°C

Contact Material: Brass
 Contact plating: Au or Sn Over Ni
 Insulator Material: PBT/PA6T+30%G.F.(UL94V-0)

Ordering Information

3110-XX S XX B K00 X3

- | | | | |
|-------------|-------------------|-----------------|----------|
| No. of Pins | Contact Plating | Color Insulator | Packing: |
| 34P | G0=Gold Flash | B=Black | A=Tray |
| 40P | G1=3u"Gold | U=Blue | T=Tube |
| | G2=5u"Gold | G=Gray(427C) | |
| | G3=10u"Gold | E=Gray(413C) | |
| | G4=15u"Gold | | |
| | G5=30u"Gold | | |
| | S0=Gold Flash/Tin | | |
| | S1=3u"Gold/Tin | | |
| | S2=5u"Gold/Tin | | |
| | S3=10u"Gold/Tin | | |
| | S4=15u"Gold/Tin | | |
| | S5=30u"Gold/Tin | | |
| | SN=Tin | | |

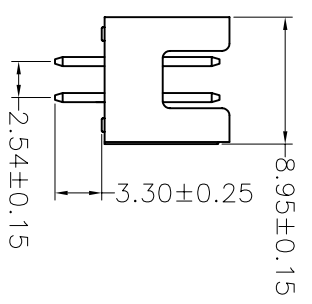
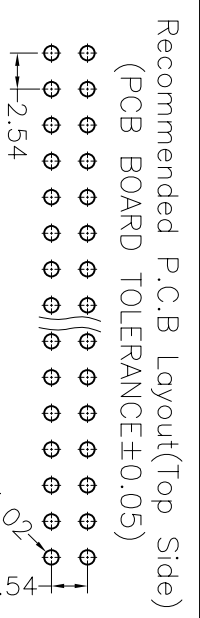
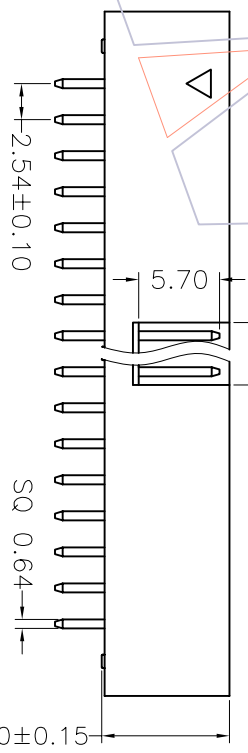
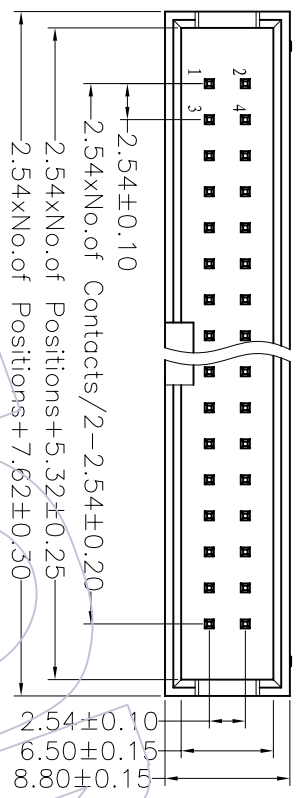

REV	DATE	MODIFICATION DESCRIPTION	CHANGE	APPROVE	OPERATION	DRAW	WEIXD	SCALE	PART NO.	TITLE:
A0	08/05/08	NEW			XXX ±0.40	DESIGN	08/05/08	2:1	3110-XXSXXBK00X3	2.54 BOX HEADER 180° H=9.0(U TYPE)
					XXX ±0.25	CHECK		A4		
					XXX ±0.15	CHECK		1/1		
					Angle ± 3'	APPROVE		PROJ.		Customer NO.

WCON 维峰五金电子有限公司
 WAFE HARDWARE ELECTRONICS CO. LTD