

# HSP

### NOTES:

Current Rating: 1.0AMP  
 Withstand Voltage: 500V AC/DC  
 Contact Resistance: 20mΩ Max  
 Insulation Resistance: 1000MΩMin  
 Operation Temperature: -40°C to +105°C

Contact Material: Phosphor Bronze  
 Contact plating: Au or Sn over Ni  
 Insulator Material: PA6T+30%G, F UL94V-0

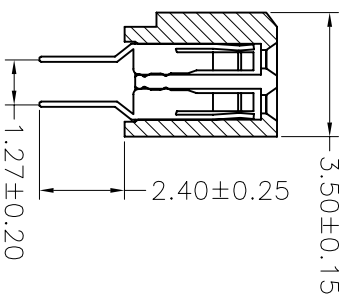
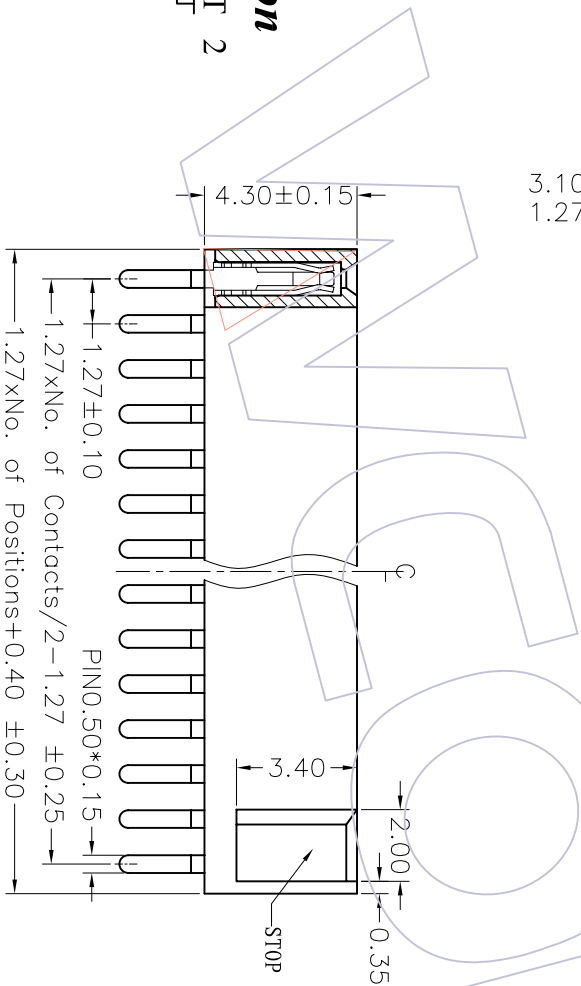
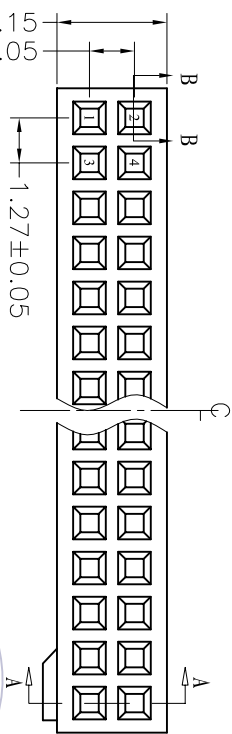
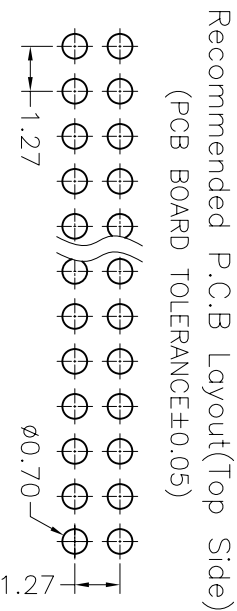

## Ordering Information

2344 - 2 XX S XX CUNT 2

No. of Pins per ROW: 02-50Pin  
 Contact Plating: G0=Gold Flash  
 G1=3μ'Gold  
 G2=5μ'Gold  
 G3=10μ'Gold  
 G4=15μ'Gold  
 G5=30μ'Gold  
 SP=Gold Flash/Tin  
 S1=3μ'Gold/Tin  
 S2=5μ'Gold/Tin  
 S3=10μ'Gold/Tin  
 S4=15μ'Gold/Tin  
 S5=30μ'Gold/Tin  
 SN=Tin

SECTION B-B

SECTION A-A

REV	DATE	MODIFICATION DESCRIPTION	CHANGE	APPROVE	OPERATION	DRAW	SCALE	PART NO.	TITLE:
A0	08/02/16	NEW			XXX ±0.25	DESIGN	3:1 mm	2344-2XXSXXCUNT2	FH1.27mm DUAL 180° H=4.30 WITH BUMP
					Angle ± 3'	CHECK	1/1		
					DIM TOL	APPROVE	PROJ.	Customer NO.	

**WCON** 维峰五金电子有限公司  
 WAFE HARDWARE ELECTRONICS CO.,LTD